

5372

Hampton R™ 72" x 42" x 23 1/2" Swirl-way® Air Massage Bath

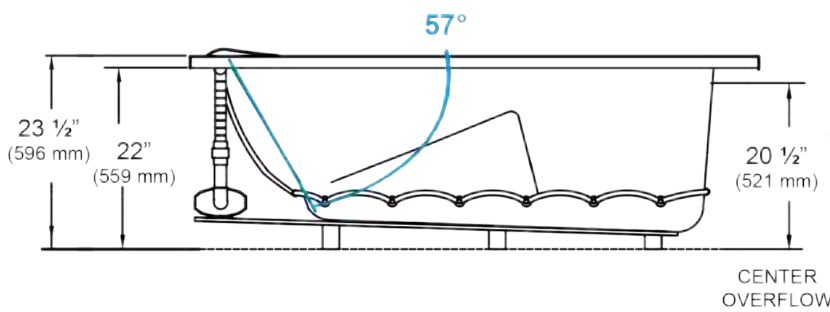
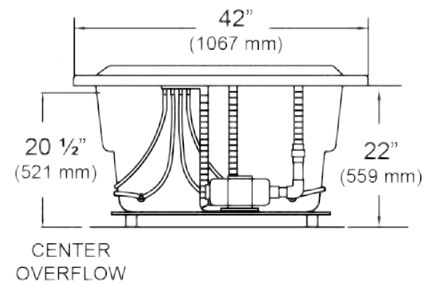
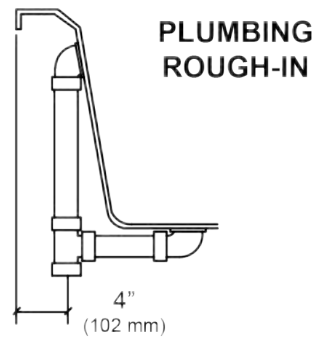
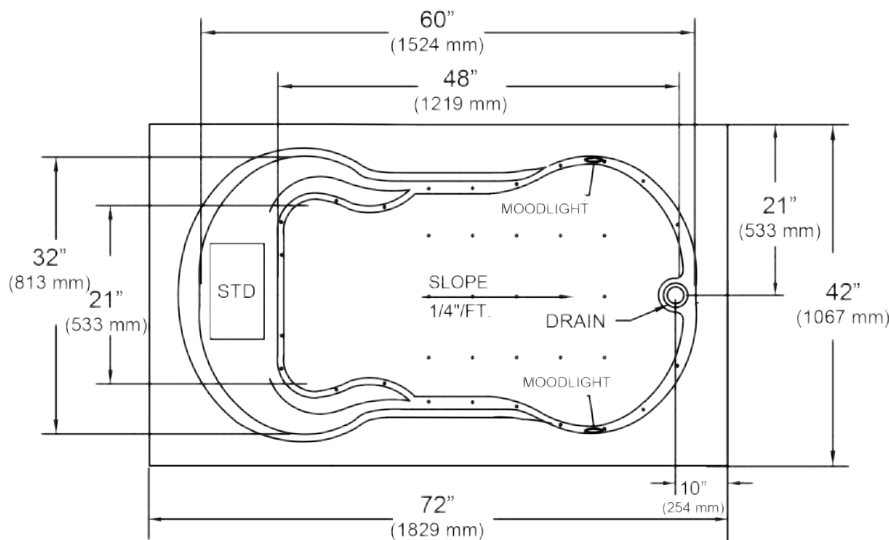

NOTES:

1. Blower location shown for clarity
2. Required blower motor access is 20" W x 15" H.
3. Measurements may vary 1/4" (+/-)
4. If a factory installed nailing flange is added to a unit, add 1/8" to each side flanged.
5. Removable apron is not available for this unit.
6. These dimensions are nominal and subject to change without notice.

SPECIFICATIONS

| Specification | Description | Specification | Description |
|--------------------------------|---------------------------------------------------------------------------|-----------------------------|----------------------------------------------|
| Material | Acrylic, fiberglass reinforced | Number of Jets | 34 |
| Construction | Self-contained, pre-plumbed air bath system mounted on a pre-leveled base | Water Capacity | 60 gal. (min) 80 gal. (max) |
| Blower Motor | 1.0 HP Variable Speed - 120 V, 9.0 AMP | Floor Loading Weight | 47 lbs. / sq. ft (229 kg/m ²) |
| Electrical Requirements | One 120V, 20 AMP, GFCI Protected Circuit | Shipping Weight | 180 lbs. |
| On/Off Control | Six button electronic control 20 minute time cycle, and auto purge cycle | Warranty | Limited Ten Year |

