

5084/5584

**MANSFIELD™**

Elba R™ 59 1/2" x 42" x 23"

Swirl-way® Whirlpool and Bathtub

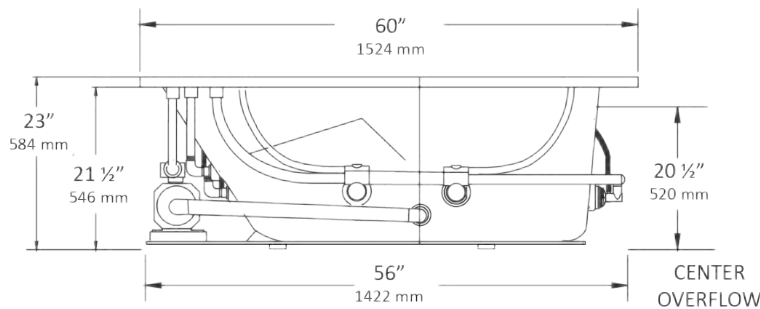
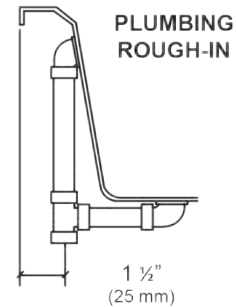
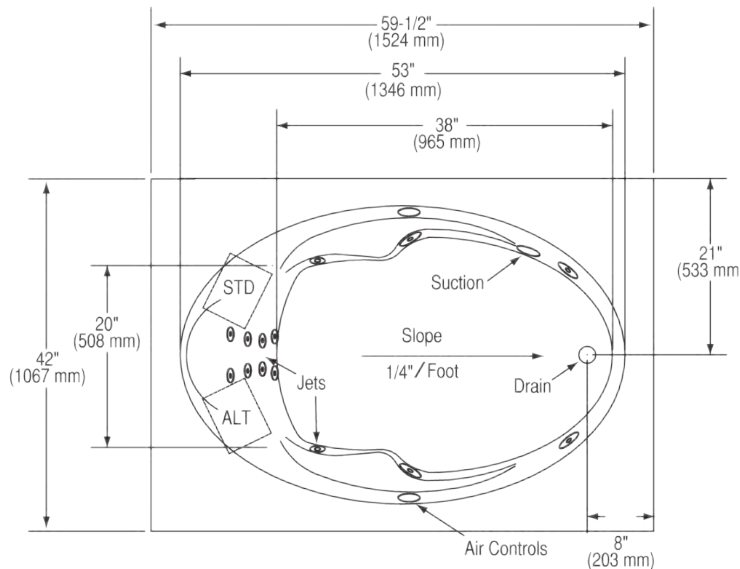

**NOTES:**

1. Pump locations shown for clarity. Choose STD or ALT upon ordering.
2. Required pump motor access is 20" W x 15" H.
3. Measurements may vary 1/4" (+/-).
4. Optional removable apron is not available on this unit.
5. Installer note: due to the freeform shape of the tub shell, it is recommended that the tub be on the job before making the final cut-out for drop-in installation.

**SPECIFICATIONS**

| Specification                  | Description   | Specification                  | Description                                   |
|--------------------------------|---|--------------------------------|---|
| <b>Material</b>                | Acrylic, fiberglass reinforced  | <b>Warranty</b>                | Limited Ten Year                              |
| <b>Construction</b>            | Self-contained, pre-plumbed whirlpool bath system mounted on a pre-leveled base                     | <b>Water Capacity</b>          | 50 gal. (min)<br>70 gal. (max)                |
| <b>Number of Jets</b>          | 14  | <b>Shipping Weight</b>         | Whirlpool - 155 lbs                           |
| <b>Floor Loading Weight</b>    | 47 lbs. / sq.ft.  |                                | Bathtub - 135 lbs                             |
| <b>ESSENTIALS PACKAGE</b>      |   | <b>COMFORT PACKAGE</b>         |   |
| <b>Pump Motor</b>              | Single speed induction pump, 13 AMP   | <b>Pump Motor</b>              | Variable speed induction pump, 13 AMP         |
| <b>On/Off Control</b>          | One button on/off electronic keypad   | <b>On/Off Control</b>          | Multi-function electronic keypad              |
| <b>Electrical Requirements</b> | One 120V, 20 amp GFCI dedicated circuit. Optional heater: separate 120 V, 20 amp dedicated circuit. | <b>Electrical Requirements</b> | Two separate 120 V, 20 amp dedicated circuits |

