

Granite Composite
 Premium Granite Composite
 Dual-mount Kitchen Sink

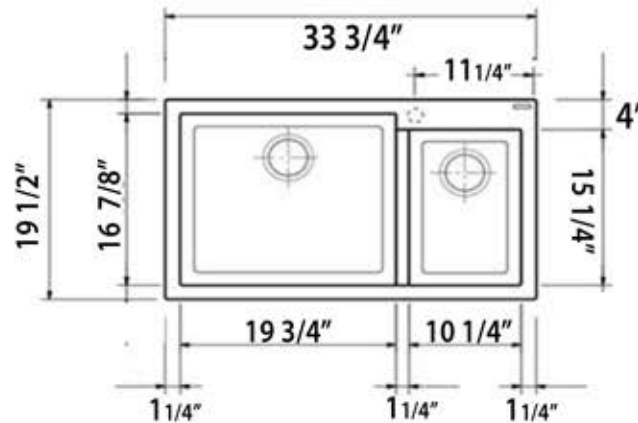

MODEL:
PR7030



1 PRE-DRILLED CENTER HOLE
 AS SHOWN IN PRODUCT IMAGE

ADDITIONAL HOLE POCKETS
 AVAILABLE ON BACK SIDE OF SINK

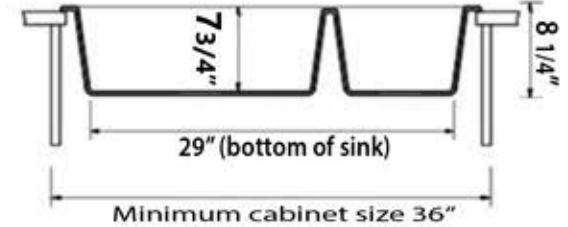

Overall Dimensions	Interior Bowls	Bowl Depth	Height	Drain Holes
33.25" x 19.5" top 29" x 16.25" bottom	19.75" x 16.875" 10.25" x 15.25"	7.75"	8.25" Overall	3.5"

FEATURES

- Premium Granite Composite Kitchen Sink
- 80% Stone/20% Resin
- Scratch Resistant/Heat resistant to 560F degrees
- Hygienic non-porous surface
- Topmount Installation
- Designed and made in Italy
- Product weight: 30lbs.
- Limited Manufacturers Warranty



PROJECT/ NAME:

ARCHITECT/CONTRACTOR:

MODEL:

JOB NOTES: