

### MOUNTING INSTRUCTIONS and PLUMBING CONNECTIONS

Refer to diagrams for plumbing rough-in. Provide solid, well-drained smooth, flat, finished surface to mount pedestal fountain (concrete pad recommended) with adequate support (300 lb. load minimum). To secure unit, use (6) 3/8" minimum fasteners (not provided).

A service supply stop must be installed at the fountain inlet line.

Trap and service stop not included.

Position pedestal over plumbing and secure base to fasteners. Remove access panels and connect supply and water lines. Turn on water supply and check for leaks. Refer to owner's manual for detailed instructions. Reassemble access panels to pedestal.

**OPERATING PRESSURES:**  
Supply water 20 – 105 psi maximum

TOP VIEW

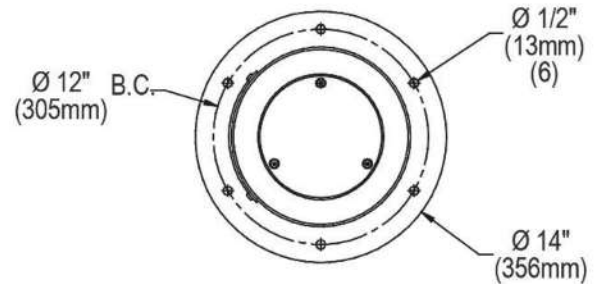

SIDE & FRONT VIEWS

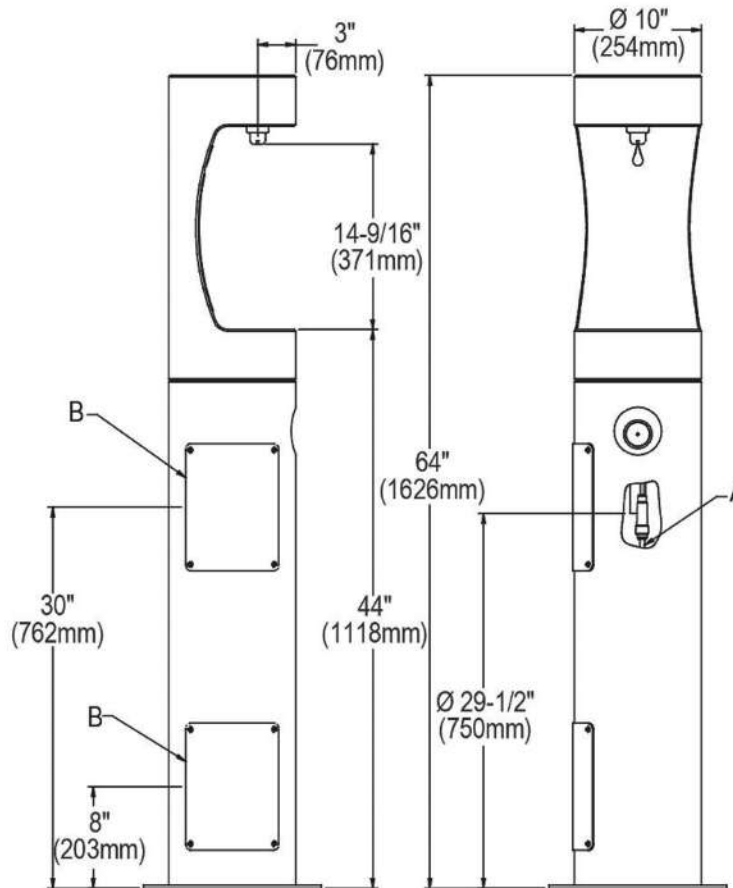

A = 3/8" O.D. Unplated copper tube connect. Shut off valve by others.  
B = Access panel(8" x 10")

*In keeping with our policy of continuing product improvement, Halsey Taylor reserves the right to change product specifications without notice. Please visit [Halseytaylor.com](http://Halseytaylor.com) for the most current version of Halsey Taylor product specification sheets. This specification describes a Halsey Taylor product with design, quality, and functional benefits to the user. When making a comparison of other producers' offerings, be certain these features are not overlooked.*