

MOUNTING INSTRUCTIONS

Refer to diagrams for rough-in of plumbing.
For wall support required locations see installation instructions provided with fountain. Bolt fountain securely to wall per installation instructions. Water supply and waste line are to be assembled as required. Final check for leaks and correct functions of fountain should be made. (For details see the installation instructions.)

Installation requires trap to be installed in wall. A service supply stop must be installed at the fountain inlet line. Trap and service stop not included.

CAUTION – Fountain must be securely bolted to wall

OPERATING PRESSURES
Supply water-105 psi maximum

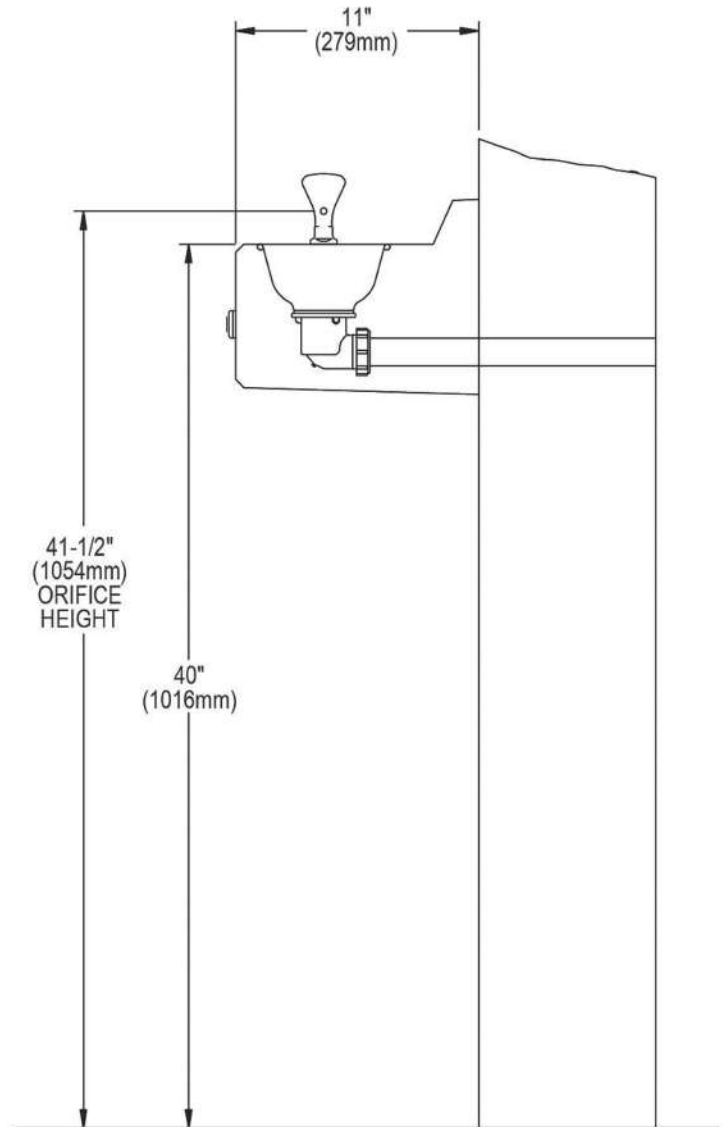
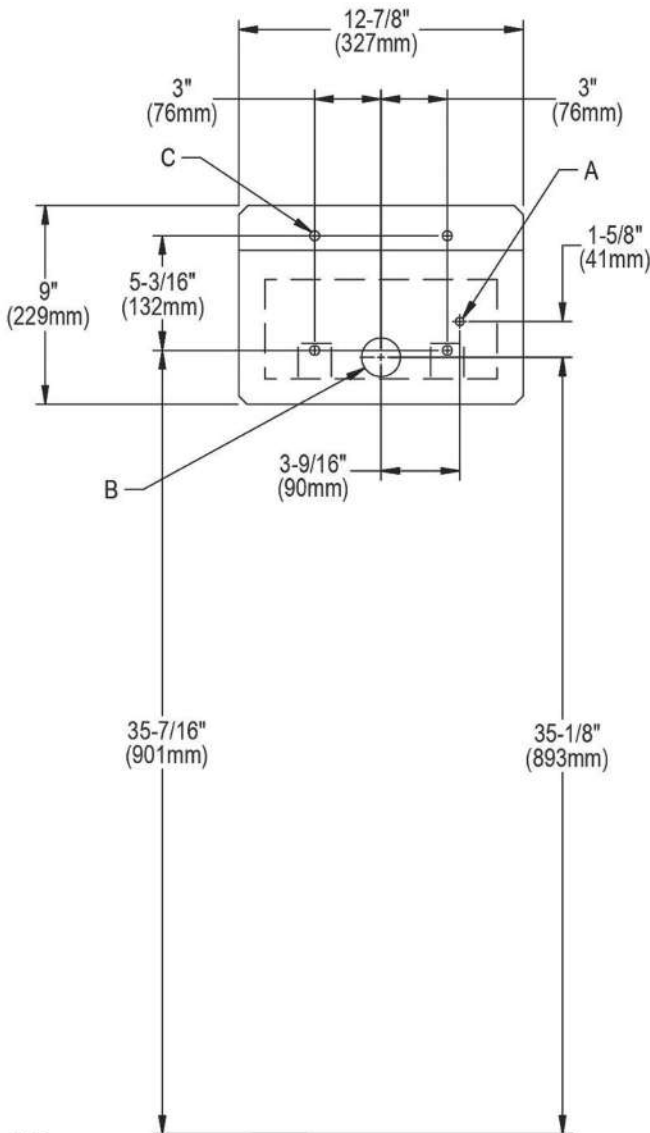

LEGEND:

A: Recommended water supply location, 3/8" O.D. unplated copper tube connect stub 1-1/2" (38mm) out from wall shut off valve by others.

B: Recommended location for waste outlet, 1-3/4" O.D. (44mm) drain.

C: (4) 5/16" (8mm) Dia. mounting holes.

Important: For recommended wall support see installation instructions provided with panel and fountains.

In keeping with our policy of continuing product improvement, Halsey Taylor reserves the right to change product specifications without notice. Please visit Halseytaylor.com for the most current version of Halsey Taylor product specification sheets. This specification describes a Halsey Taylor product with design, quality, and functional benefits to the user. When making a comparison of other producers' offerings, be certain these features are not overlooked.