

WATER VALVE RETROFIT

MODELS: 125B



WARNING

LP & NG ARE EXTREMELY FLAMMABLE SO
TAKE EXTRA PRECAUTIONS WHEN
PERFORMING ANY WORK TO THE HEATER

Introduction

The original equipment brass water valve on the 125B water heater has been discontinued and will need to be replaced with the higher quality plastic version. The kit you have received will allow your heater to be upgraded to this newest version of the water valve.

A complete kit to replace the 125B Brass Water Valve Assembly consists of these parts:

- a. Plastic water valve with bracket
- b. Venturi
- c. Retaining pin (for cold water pipe)
- d. Cold water pipe (from water valve to heat exchanger inlet)
- e. Rubber O-ring
- f. Hot water outlet pipe (from heat exchanger outlet)
- g. Small fiber washer for hot water outlet pipe
- h. 2 large fiber washers for inlet and outlet connections (2)

A. Preparation

Tools Needed:

- Philips head and flat screwdriver
- Medium sized adjustable wrench
- Container to catch water

Shut off gas and water supply to heater and open a faucet to relieve pressure in water line.

For steps below refer to Figure 1, Page 2

1. Pull off flow knob and unscrew collar, then lift up and pull cover off.
2. Complete draining of the 125B by removing drain screw (1), then disconnect the cold water inlet fitting (2) at the back of water valve, have container ready for remaining water. After draining, replace drain screw. Disconnect the hot water outlet fitting (3) from back of water valve.
3. Remove cold water pipe (4) from right side of water valve (5) and inlet to heat exchanger, discard or recycle.
4. Locate ECO (6) on hot water outlet pipe and carefully remove two wires. Remove ECO by carefully unscrewing, retain the ECO, it will be needed later.
5. Remove hot water outlet pipe (7) from left side of water valve (8) and heat exchanger, discard or recycle.

B. Removing the brass water valve assembly

1. Two set screws are now holding water valve up against gas valve. Locate set screws (see picture below), access front screw through the hole on front control plate with a screwdriver. Support water valve with one hand and loosen both set screws, once loose the valve will drop downward. If Set screws do not unscrew easily **do not force them** you could damage the gas valve. Try a descaling solution (white vinegar, CLR® or other descaling solution) on screw threads. Let sit for 1 hour, try again to remove set screw(s) without forcing.
- If still unable to remove, Call 800-642-3111 for help

C. Installing Plastic Water Valve, refer to Figure 2

1. Insert venturi (B) with o-ring end first into right side of plastic water valve cold water outlet (J). Push in gently to make sure it is seated in place.
2. Attach plastic water valve (A) to gas valve using set screws described in step B1, making sure water valve top is flush to bottom of gas valve, begin to tighten evenly but leave screws a little loose for now. We suggest use of an anti seize compound on screw threads. Cold inlet and hot outlet connections should be facing the back.
3. Place rubber o-ring (E) onto end of new cold water pipe (D), insert the other end of the new cold water pipe into inlet of heat exchanger and loosely tighten retaining nut. Insert o-ring end into right side of water valve (J) and push in firmly. Insert retaining pin (C) from top into two holes to hold pipe in water valve. Retaining pin should go all the way in for connection to be correct. Tighten retaining nut on inlet pipe to heat exchanger.
4. The new hot water outlet pipe (F) now needs to be installed. The end with the threaded fitting needs to be inserted into bracket on back of water valve (Figure 3). From the front, gently push towards the wall on bracket end and insert threaded fitting into bracket. Using the small fiber washer (G), connect the other end of the hot water pipe to the heat exchanger outlet and tighten.
5. Tighten water valve set screws left loose in step C2.

WATER VALVE RETROFIT

6. Install ECO (#6 from Figure 1) into threaded fitting (I) on new hotwater pipe. Reattach two wires to ECO, there is no polarity so it does not matter which goes where.
7. Using two new large fiber washers (H), reconnect cold water inlet (Fig 1, # 2) and hot water outlet (Fig 1, # 3) to back of water valve.

D. Testing operation

1. **Important:** Before firing the unit, run water through heater to test for water leaks and purge all air.
2. Shut water off at inlet supply. Replace front cover and the flow control collar and knob.
3. Light pilot and position slide control to three flame setting.
4. Set flow dial all the way clockwise. Now slowly open inlet water supply until burners ignite. Stop there. Measure flow at open outlet to verify proper activation of a 1/2 gallon per minute flow rate (1/2 gpm = a quart in 30 seconds or a gallon in 120 seconds or less).
5. Shut water off and verify burners deactivate when water flow stops.



Figure 3
 Detail of hot water outlet pipe and bracket (step C4)

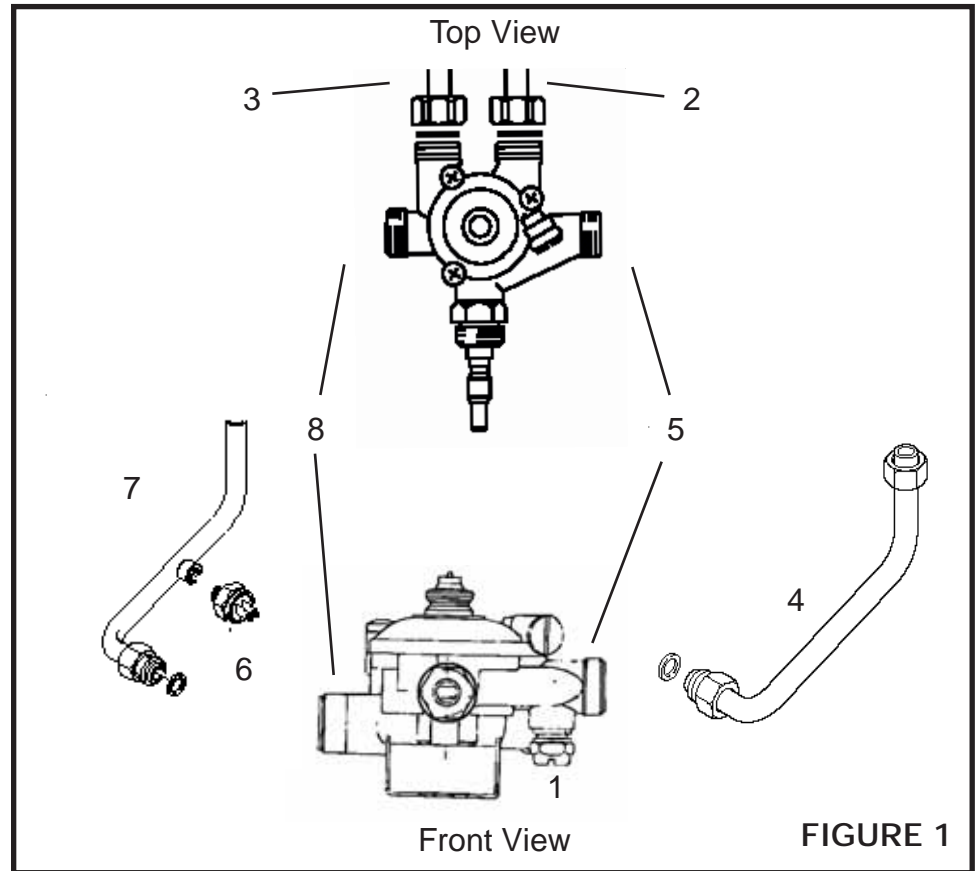

FIGURE 1

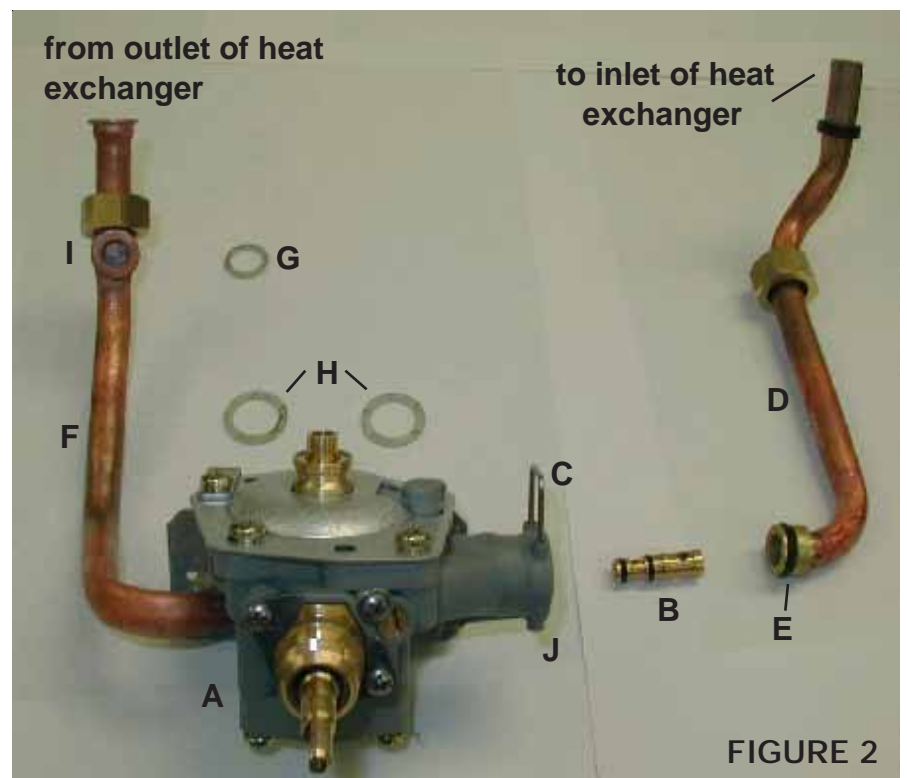

FIGURE 2