

## Instructions:

1. Shut off water supply & disconnect.
2. Unbolt tank from bowl.
3. Remove old flush valve & flapper.
4. Install new flush valve as shown. (4a)
5. Check height of flush valve. (5a)

Top of flush valve should be no more than  $3/4$ " above water line marked in tank. Verify top of flush valve is at least 1" below bottom of flush lever nut.

Note: Verify C/L line (critical level) on fill valve or ballcock is at least 1" above top of overflow tube. This is a plumbing code requirement.

Caution: If the top of the overflow tube in your toilet is higher than the flush lever opening, water could leak out.

6. Reassemble tank to bowl.
7. Reattach refill tube and install flapper. (7a)
8. Connect water supply line & turn on water supply.

4a.

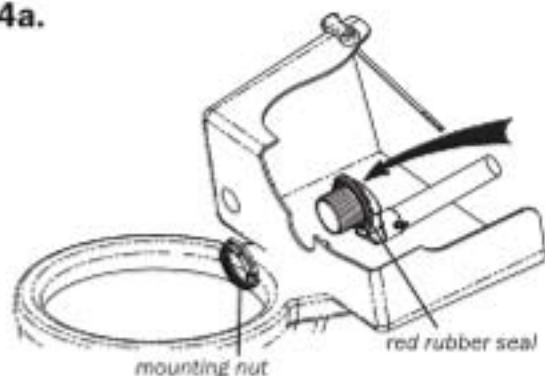

5a.

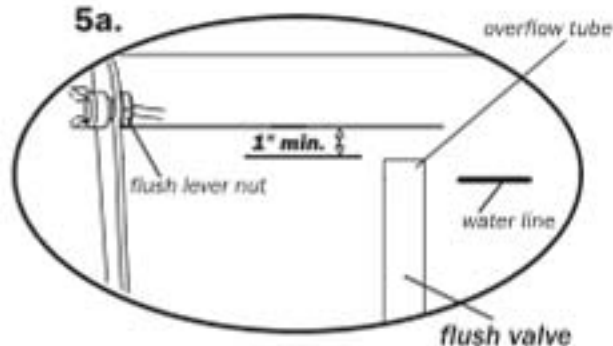

6a.

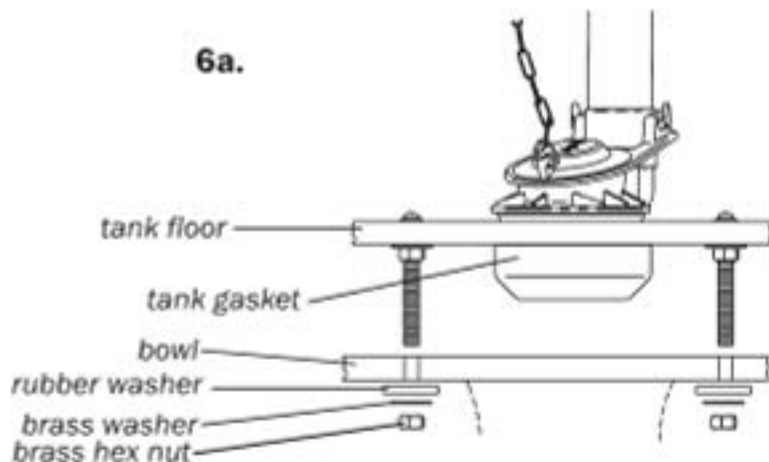

7a.

