

TRU-GAP AIR GAP FIXTURE

Item# Submitted	_____
Job Name	_____
Location	_____
Engineer	_____
Contractor	_____
PO#	_____ Tag _____

SPECIFICATION

TRU-GAP is built for the plumbing, water conditioning, beverage vending, food service and other industries. The unique design of the TRU-GAP allows for nearly countless applications for a proper air gap waste.

MATERIALS

Drain Body: (PVC) ASTM D2665
Tube support mount: (PVC) ASTM D2665
Hardware: Stainless Steel

INSTALLATION

TRU-GAP can be connected by solvent weld to a standard 2" PVC DWV pipe and with PVC reducer fittings can be adapted to smaller or larger piping.



DIMENSIONS

- A: Bottom ID.....2.39"
- B: Overall Width.....4.625"
- C: Body Height.....2.97"
- D: Bottom to center line.....5.56"
- E: Overall Height.....6.56" (shown)
 Note – dependant on tube diameter

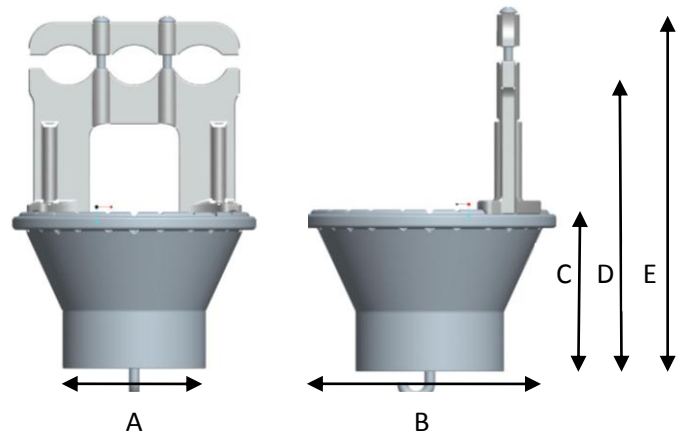

REGULATORY

TRU-GAP product is tested to full compliance to the ASTM D2665 standard by CRT Laboratories Incorporated; CRT Laboratories is certified under ISO-IEC 17025:2005 by “The International Association for Plumbing & Mechanical Officials” (IAPMO), ensuring that all technicians involved with testing are trained and highly qualified.